



LC3000

REV1.1-Revised AUG 2008

High Efficiency Low Noise PFM Step-up DC/DC Converter

DESCRIPTION

LC3000 series are CMOS-based PFM step-up DC-DC Converter. The converter can start up by supply voltage as low as 0.8V, and capable of delivering maximum 200mA output current at 3.3V output with 1.8V input Voltage. Quiescent current drawn from power source is as low as 20uA. All of these features make LC3000 series be suitable for the portable devices, which are supplied by a single battery to four-cell batteries.

To reduce the noise caused by the switch regulator, LC3000 is well considered in circuit design and manufacture. So that the interferer to other circuits by the device is reduced greatly.

LC3000 integrates stable reference circuits and trimming technology, so it can afford high precision and low temperature-drift coefficient of the output voltage.

LC3000 is available in SOT-89-3, SOT-23-3 and SOT-23-5 packages that is PB free. And in 5-pin packages, such as SOT-23-5, the device can be switch on or off easily by CE pin, to minimize the standby supply current.

TYPICAL APPLICATION

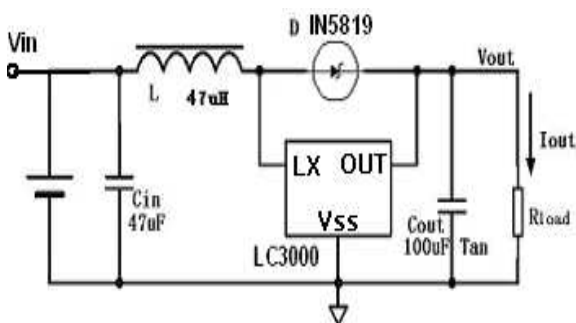

FEATURES

- Deliver 200mA at 3.3V Output voltage with 1.8V input Voltage
- Low start-up voltage (when the output current is 1mA)-----0.8V
- Output voltage can be adjusted from 2.5V to 6.0V (In 0.1V step)
- Output voltage accuracy ----- $\pm 2\%$
- Low temperature-drift coefficient of the output voltage----- $\pm 100\text{ppm}/^\circ\text{C}$
- Only three external components are necessary: An inductor, a Schottky diode and an output filter capacitor
- Low quiescent current drawn from power source----- $< 20\mu\text{A}$

APPLICATIONS

- Power Source for PDA, DSC, MP3 Player, Electronic toy and wireless mouse
- Power Source for a Single or Dual-cell Battery-Powered Equipments
- Power Source for LED

ELECTRICAL CHARACTERISTICS

