



# LC2316

## 1.2A Step-down DC-DC Converter

### DESCRIPTION

LC2316 is a current mode PWM step-down DC-DC converter, which has an internal 2A power switch. It has the wide input voltage range of 3.6V to 20V, so it can suit for regulating a wide variety of power source.

LC2316 use bipolar technology and make of a PWM control circuit, a reference voltage unit, an error amplifier, a protection circuit, Chip Enable circuit, and under voltage lockout circuit. A low ripple, high efficiency step-down DC-DC converter can be easily composed of this IC with only several external components, or an inductor, a diode and capacitors. Output Voltage can be adjusted with external resistors.

The LC2316 has the cycle-by-cycle current limit circuit; current limiting provides protection against shorted output. The low current (<1uA) shutdown provides complete output disconnect, enabling easy power management in battery powered systems.

### FEATURES

- ◆ Range of Input Voltage: 3.6V~20V
- ◆ Built-in NPN switch
- ◆ <1μA Shutdown Current
- ◆ Oscillation Frequency: 1.2MHz
- ◆ High efficiency: 90%
- ◆ High Accuracy Output Voltage: ± 2%
- ◆ Low Temperature-Drift Coefficient of Output Voltage: Type: ± 100ppm/°C
- ◆ Operating Temperature Range: -40°C ~85°C
- ◆ Demo Board Available

### APPLICATIONS

- ◆ Power source for hand-held communication equipment, cameras, video instruments such as VCRs, camcorders.
- ◆ Power source for battery-powered equipment.
- ◆ Power source for household electrical appliance

### ORDERING INFORMATION

LC2316 [1](#) [2](#) [3](#)

Code	Description
<a href="#">1</a>	Temperature & Rohs: C: -40~85°C, Pb Free Rohs Std.
<a href="#">2</a>	Package Type: D8: SOP-8
<a href="#">3</a>	Packing Type: TR: Tape & Reel (Standard)

### PIN CONFIGURATION

Product Classification		LC2316CD8TR
Marking		
HF XX YYBZZ	HF: Product Code	
	XX: Output Voltage Adjustable	
	YY: LOT NO.	
	B: FAB Code	
	ZZ: Date Code	

## PIN DESCRIPTION

Pin No.	Symbol	Description
1	BOOST	Boost Pin
2	VIN	Power Supply Pin
3	SW	Switching Node: PWM output connection to inductor.
4	GND	Ground Pin
5	FB	Pin for Feedback Voltage
6	NC	Not Connected
7	CE	Chip Enable Pin (Active with "H")
8	NC	Not Connected

## BLOCK DIAGRAM

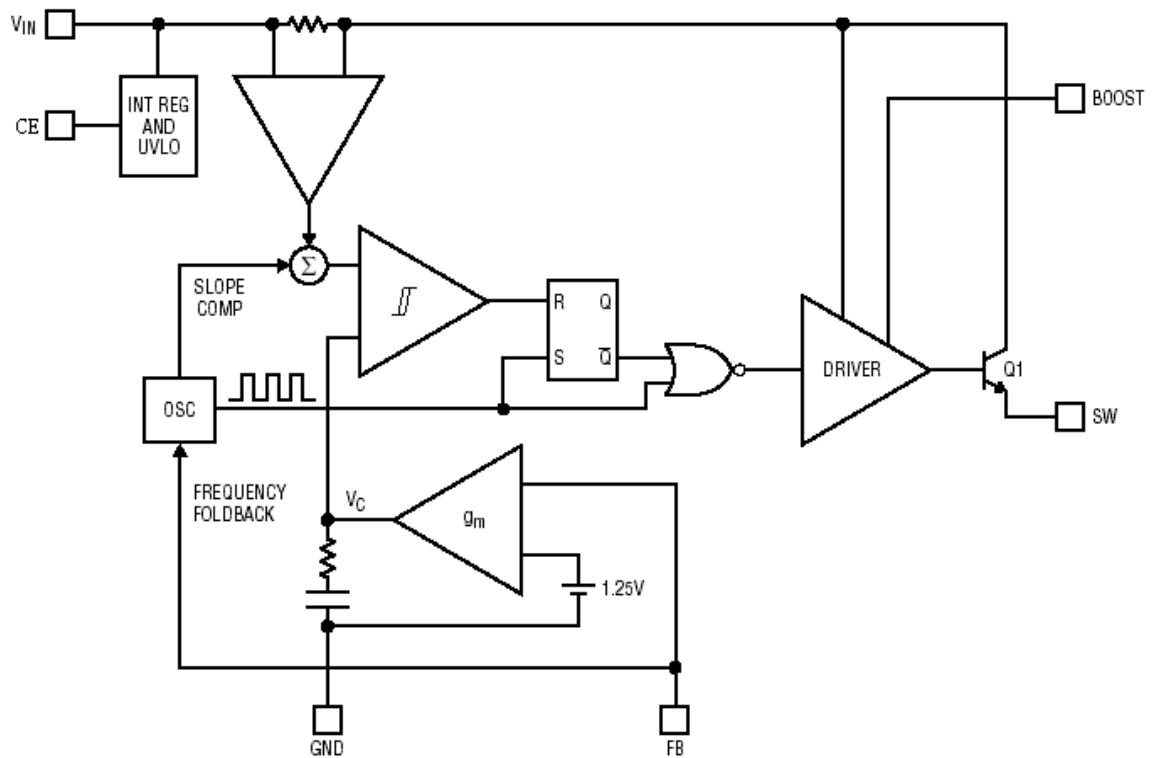

## ABSOLUTE MAXIMUM RATING

Supply Voltage	25V
Boost Pin Voltage	35V
Boost Pin Above SW Pin	25
CE Pin Voltage	-0.3V to Vin+0.3V
FB Pin Voltage	-0.3V to 6V
Operating Ambient Temperature Range	-25°C to 85°C
Storage Temperature Range	-40°C to 150°C
Lead Temperature (Soldering, 10 sec)	260°C
Thermal resistance: $\Theta_{JA}$	150°C/W

## ELECTRICAL CHARACTERISTICS

(Test condition is in 25°C, VIN=12V, VBOOST=17V, unless otherwise noted.)

Symbol	Item	Conditions	Min.	Typ.	Max.	Unit
VUVLO	Under voltage Lockout			3.35	3.6	V
VFB	Feedback Voltage		1.225	1.25	1.275	V
IFB	FB Pin Bias Current	VFB=1.25V		150	600	nA
IQ	Quiescent Current	VFB=1.3V		2		mA
	Quiescent Current in Shutdown	VCE=0V			2	uA
$\Delta VFB/\Delta V$	Reference Line Regulation	VIN=5V to 20V		0.08		%/V
$\Delta VFB/\Delta T$	Feedback Voltage Temperature Coefficient	-25°C ≤ T <sub>opt</sub> ≤ 85°C		±100		ppm/°C
FOSC_MAX	Oscillator Frequency	VFB=1.1V		1.2		MHz
FOSCTH	Frequency Shift Threshold on FB Pin	FSW=700K		0.44		V
DMAX	Max Duty Cycle			88		%
ILIMIT	Switch Current Limit	VIN=10V		2.5		A
VCESAT	Switch Saturation Voltage	ISW=300mA		220	350	mV
ISW	Switch Leakage Current				1	uA
ICEH	CE "H" Input Current	VCE =3V		6.5	15	μ A
ICEL	CE "L" Input Current	VCE = 0V		0.03	0.1	μ A
VCEH	CE "H" Input Voltage	VIN = 12V	1.8			V
VCEL	CE "L" Input Voltage	VIN = 12V			0.4	V

## TYPICAL APPLICATION

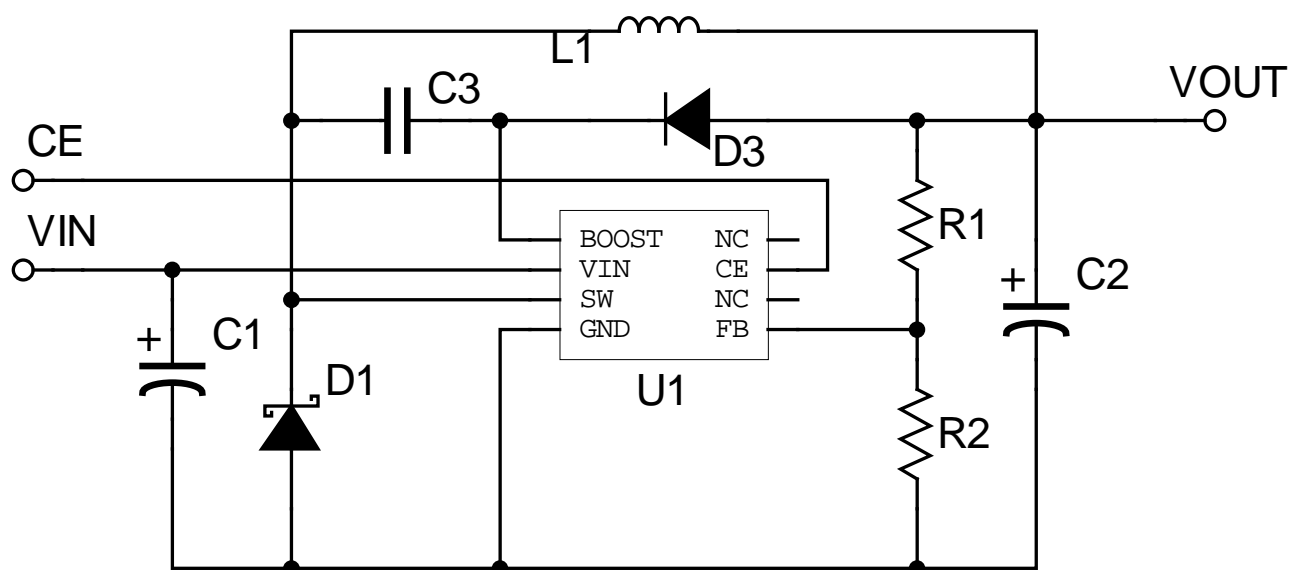

## DEMO BOARD BOM

### ➤ Table 1 Bill of Materials

No.	Reference	Type	Specification	Note
1	C1	Capacitor	Tantalum Capacitor; 25V/47uF; SMD	
2	C2	Capacitor	Tantalum Capacitor; 25V/22uF; SMD	
3	C3	Capacitor	MLCC 10nF; SMD 0805	
4	D1	Diode	SS34; 40V, 3A; SMD	
5	D2	Diode	1N4148; 75V; 100mA; SMD 1206	
6	L1	Inductor	10uH; 3A; SMD, Shielding	
7	IC1	IC	LC2316; SMD SOP-8	
8	R1	Resistor	SMD 0805; 1%	Note 1
9	R2	Resistor	SMD 0805; 1%	Note 1

Note1: For VOUT=5V, R1 is 9.1K and R2 is 3K.  
For VOUT=3.3V, R1 is 3.3K and R2 is 2K.

## DEMO BOARD MEASUREMENT

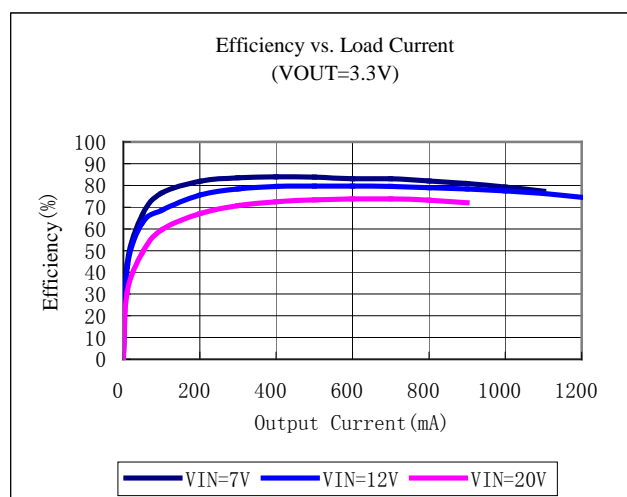
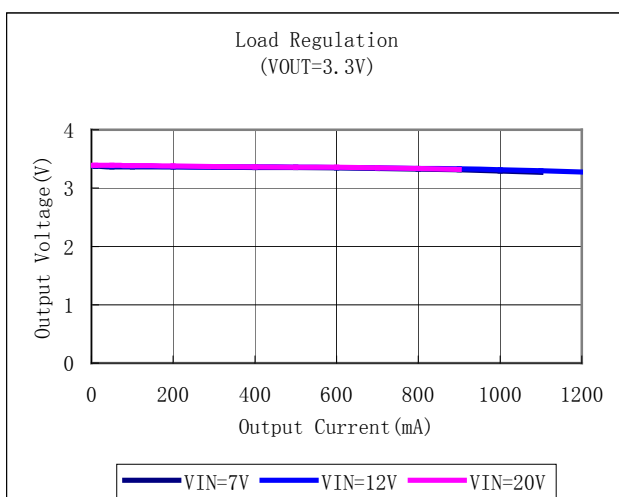
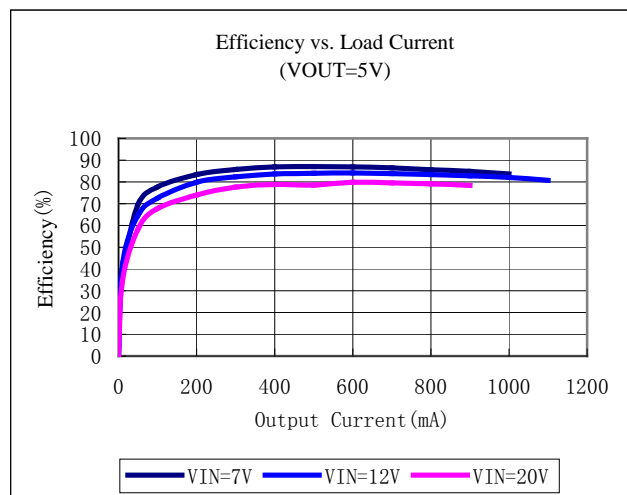
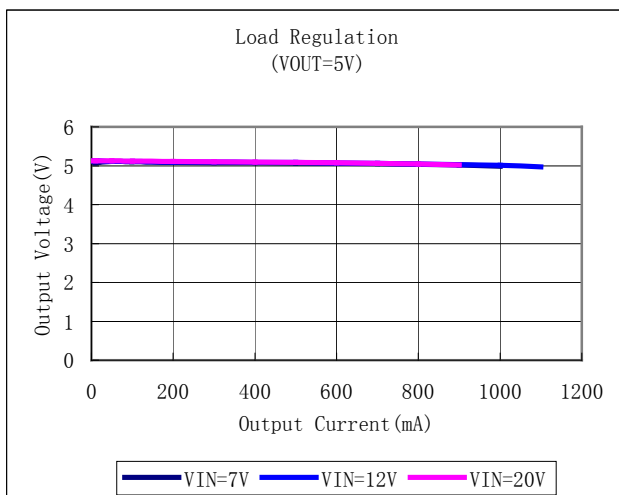

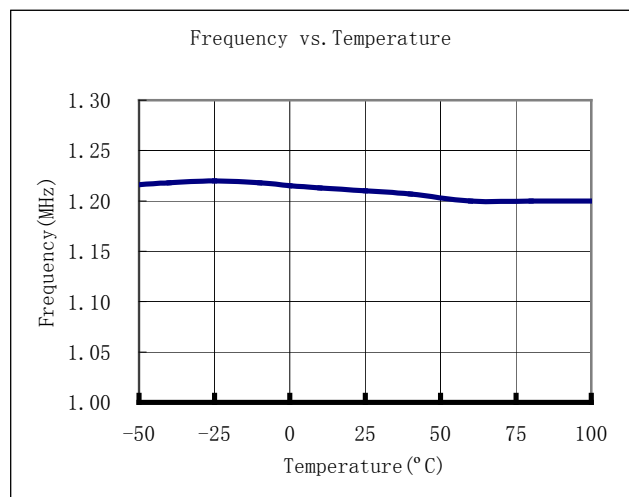
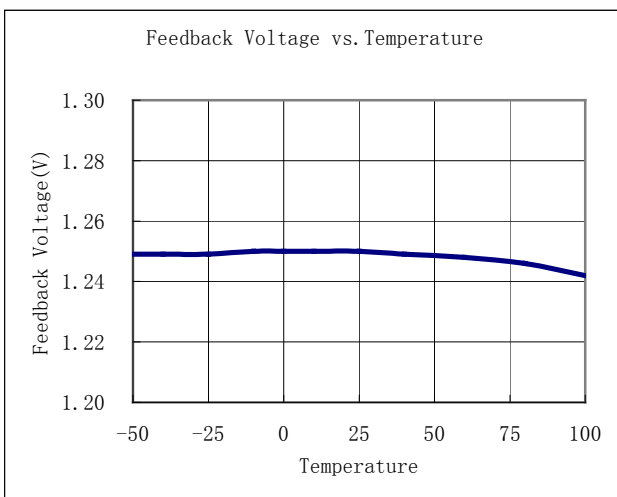
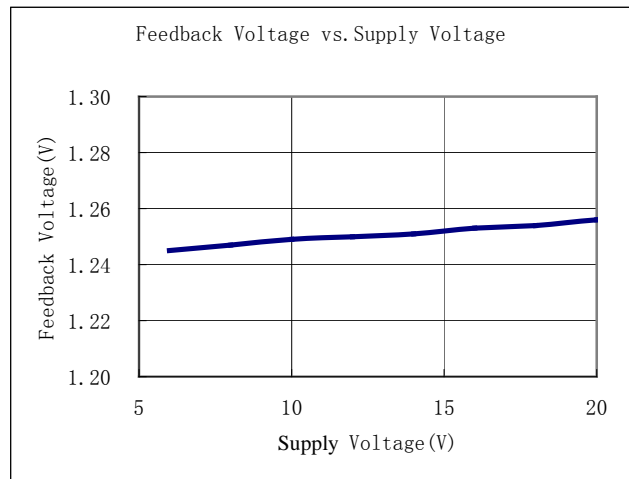
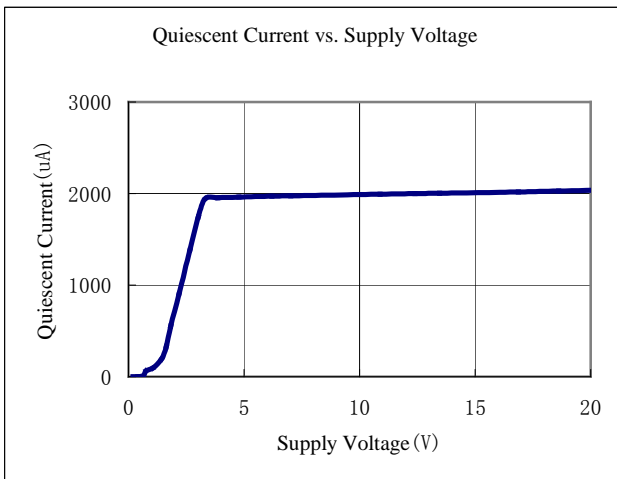

## APPLICATION INFORMATION

### Inductor Selection and Maximum Output Current

The duty cycle of the internal switch is:

$$D = (V_{OUT} + V_D) / (V_{IN} - V_{SW} + V_D)$$

In which  $V_D$  is the forward voltage drop of the catch diode (D1) and  $V_{SW}$  is the voltage drop of the internal switch. The value of duty cycle at full load current is of special interest, when values of  $V_{SW}$  and  $V_D$  can both assumed to be 0.4V.

Since LC2316 has a maximum guaranteed duty cycle of 88%, the minimum input voltage is limited for a particular value of output. When the switch is off, the voltage drop across the inductor is equal to output voltage plus the catch diode drop. Therefore the peak-to-peak ripple current in the inductor can be derived:

$$\Delta I_L = (1 - D)(V_{OUT} + V_D) / (L \cdot F_{OSC})$$

In which  $F_{OSC}$  is the switching frequency and  $L$  is the value of the inductance. The average inductor current is equal to the output current and the peak inductor current is the sum of the output current and one half of the ripple current:

$$I_{LPK} = I_{OUT} + \Delta I_L / 2$$

This current has to be kept below the maximum allowed switch current ( $I_{LIMIT}$ ) for output regulation. Typical values of  $I_{LIMIT}$  are above 2.5A and the maximum output current is

$$I_{OUT} (MAX) = I_{LIMIT} - \Delta I_L / 2$$

If the ripple current is small, then the available output current is close to the switch current limit. It is recommended that the inductor value be chosen such that the peak-

to-peak inductor ripple current is equal to one third of switch current limit. Hence the value of inductance and the maximum output current can be expressed as:

$$L = 3(1 - D)(V_{OUT} + V_D)/(I_{LIMIT} \cdot F_{OSC})$$

and

$$I_{OUT} (MAX) = (5/6) I_{LIMIT}$$

From above discussion it is derived that the switch current limit is dependant on the duty cycle, which also is a function of input voltage. For a specific application, one can calculate the value of inductance and the range of available output current according to the maximum and minimum allowed input voltage values.

## Capacitor Selection

The input capacitor (C1) supplies the AC component of the current drawn by the converter. A 10uF ceramic capacitor is sufficient in most cases.

In case the application circuitry has relatively large parasitic parameters (most often caused by long wires or filter components), additional bulk input capacitance may be required. For high-power applications it is suggested to increase the input capacitance to 100uF.

The output capacitor filters the square wave generated by the chip to produce the DC output and stores energy to supply transient loads as well as stabilizes the control loop. While for most switching mode converters, the output ripple is mainly determined by the equivalent series resistance (ESR) of the output capacitor, the LC2316's control loop is independent on the output capacitor's ESR for stable operation. If a low ESR capacitor is selected, for example ceramic capacitor, Output ripple can be estimated by the following equation:

$$V_{RIPPLE} = \Delta I_L \cdot [ESR + 1/(8 \cdot F_{OSC} \cdot C_2)]$$

The output capacitor must have an energy capacity larger than the inductor-otherwise the transfer of energy from the inductor to the output can cause large overshoot. For a 5% overshoot, the minimum value of the output capacitor can be presented as:

$$C_2 \geq 10 \cdot L \cdot (I_{LIMIT} / V_{OUT})^2$$

Good transient performance also requires

large output capacitance. The above equation also offers a good starting point for obtain the proper output capacitance value to achieve satisfactory performance.

Application engineers can start with the datasheet recommended value.

The high performance (low ESR), small size and robustness of ceramic capacitors make them the preferred type for LC2316 applications. One needs keep in mind that not all ceramic capacitors are the same. Many of the higher value capacitors use poor dielectrics with high temperature and voltage coefficients.

## Catch Diode

Schottky diode with 3A current rating is recommended for the catch diode D1.

## BOOST Pin Considerations

In the application circuit shown in the cover page, capacitor C3 and diode D2 are used to boost input voltage to a higher level. In most cases a 10nF capacitor and a fast switching diode are suitable for this purpose. The voltage at the BOOST pin must be at least 2.5V higher than the SW pin for best efficiency.

The minimum operating voltage of an LC2316 application is limited by the under voltage lockout (< 3.6V) and by the Maximum duty cycle as outlined above.

For proper startup, the boost circuit also limits the minimum input voltage. If the input voltage is ramped slowly, or the LC2316 is turned on with its CE pin when the output is already in regulation, then the boost capacitor may not be fully charged. Because the boost capacitor is charged with the energy stored in the inductor, the circuit will rely on some minimum load current to get the boost circuit running properly. This minimum load will depend on input and output voltages, and on the arrangement of the boost circuit. The minimum load generally goes to zero once the circuit has started. In many cases the discharged output capacitor will present a load to the switcher, which will allow it to start.

## PACKAGE LINE

Package	SOP-8	Devices per reel	2500Pcs	Unit	mm
---------	-------	------------------	---------	------	----

Package specification:

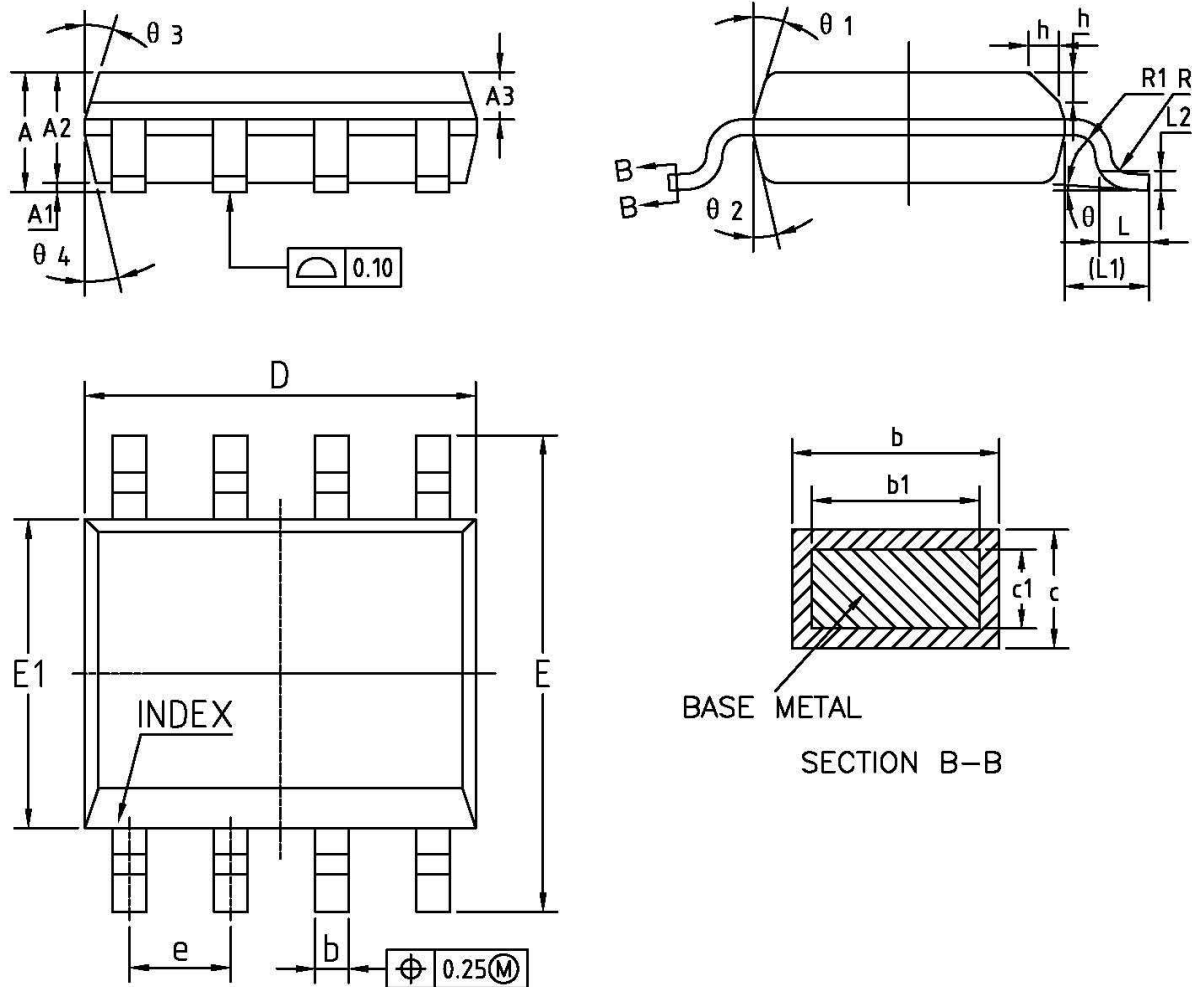

Symbol	Dimension (mm)			Symbol	Dimension (mm)		
	MIN	NOM	MAX		MIN	NOM	MAX
A	-	-	1.77	D	4.7	4.9	5.1
A1	0.08	0.18	0.28	E	5.8	6	6.2
A2	1.2	1.4	1.6	E1	3.7	3.9	4.1
A3	0.55	0.65	0.75	e	1.27BSC		
b	0.39	-	0.48	L	0.5	0.65	0.8
b1	0.38	0.41	0.43	L1	1.05BSC		
c	0.21	-	0.26	θ	0	-	8°